

AGITATOR 0.6m : TECHNICAL FEATURES

AG 010

CODE

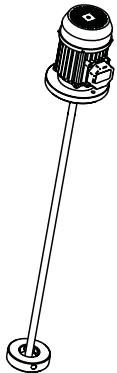

70 - P B - C 0620 - T06 P

Material	P: PP, AISI304
Turbine	T06: Ø 60
Length	0620 mm
Ø Shaft	C: Ø 15 mm
Support	B: Flange
Motor	P: 3ph 67W T56 Q: 1ph 50Hz 67W T56

MODELS

Flange	CODE	Motor		Dimensions						Agitation			
		Watts	rpm	L	Ø T	Ø Dmax	Volume	Flow					
				mm	in	m	in	m	in	m ³	gal	m ³ /h	gpm
3ph 50Hz	70-PB-C0620-T06P	67	1400	620	24.5	0.5	20	0.5	20	0.15	40	1.1	4.8
3ph 60Hz	70-PB-C0620-T06P	80	1650	620	24.5	0.6	23	0.6	23	0.2	52	1.4	6
1ph 50Hz	70-QB-C0620-T06P	67	1400	620	24.5	0.5	20	0.5	20	0.15	40	1.1	4.8

DIMENSIONS

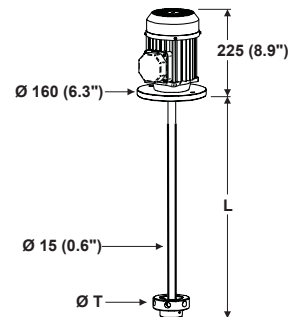
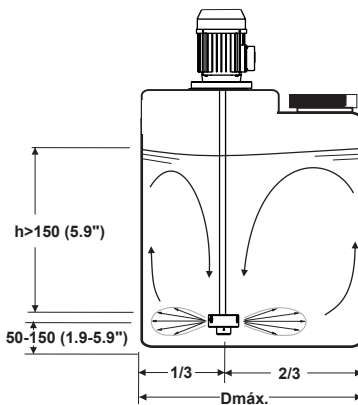

MATERIALS

Turbine	PP
Shaft	AISI 304 / PE
Screws	AISI 304
Flange	PP

MOTOR

	3ph
Power	67W (0,09Hp)
Voltage	230V - 430V
Current	0.8A - 0.45A
Frequency	50Hz - 60Hz
r.p.m	1400 - 1650
Protection	IP-55
Class	F
Frame	T56 B14