

AGITATOR 1.1m: TECHNICAL FEATURES

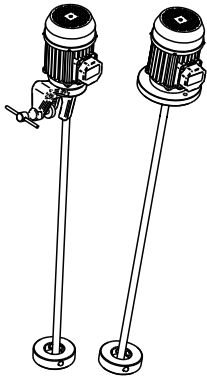

AG 011

CODE



70 - J B - A 1100 - T09 P

Material	P: PP, AISI304
Turbine	T09: Ø 90
Length	1100 mm
Ø Shaft	B: Ø 20 mm
Support	B: Flange P: Clamp
Motor	J: 3ph 185W T63 K: 1ph 50Hz 185W T63 D: 12VDC 130W T71

MODELS

		Code	Motor		Dimensions				Agitation					
			Watts	rpm	L mm	in	Ø T mm	in	Ø Dmax m	in	Volume m3	gal	Flow m3/h	gpm
 Flange	3ph 50Hz	70-JB-B1100-T09P	185	1400	1100	43	90	3.5	0.8	31	0.6	160	1.6	7
	3ph 60Hz	70-JB-B1100-T09P	222	1650	1100	43	90	3.5	0.9	35	0.8	210	2	8.8
	1ph 50Hz	70-KB-B1100-T09P	185	1400	1100	43	90	3.5	0.8	31	0.6	160	1.6	7
	12VDC	70-DB-B1100-T09P	130	1400	1100	43	90	3.5	0.8	31	0.6	160	1.6	7
 Clamp	12VDC	70-DB-P1100-T09P	130	1400	1100	43	90	3.5	0.8	31	0.6	160	1.6	7

DIMENSIONS

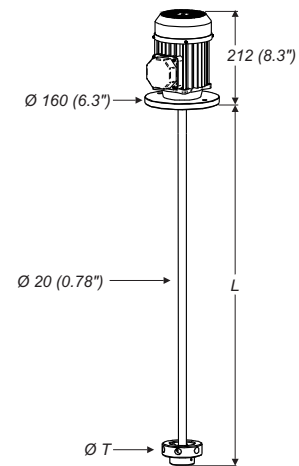
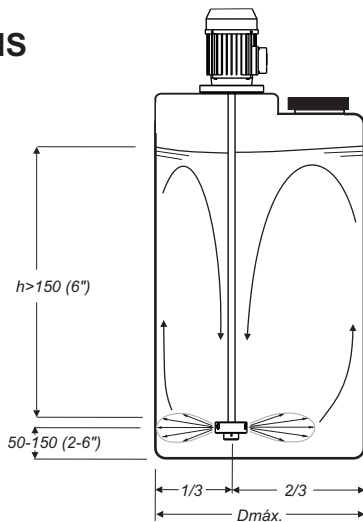

MATERIALS

Turbine	PP
Shaft	AISI 304 / PE
Screws	AISI 304
Flange	PP

MOTOR

	3ph	12VDC
Power	185W (0,25Hp)	130W(0,17Hp)
Voltage	230V - 430V	12V DC
Current	1.5A - 0,9A	15A
Frequency	50Hz-60Hz	
r.p.m	1400 - 1650	1400
Protection	IP-55	IP-20
Class	F	B
Frame	T63 B14	T71 B14