

AGITATOR 1.5m: TECHNICAL FEATURES

AG 013

CODE

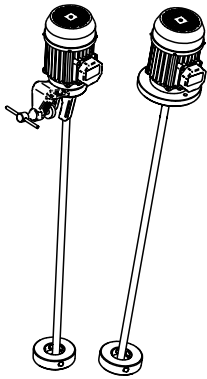

70 - LB - A 1500 - T15 P

| | |
|----------|---|
| Material | P: PP,A ISI304 |
| Turbine | T15: Ø 150 (50Hz) T13: Ø 130 (60Hz) |
| Length | 1500m m |
| Ø Shaft | A: Ø 25 mm |
| Support | B: Flange P: Clamp |
| Motor | L: 3ph 750w 1500rpm M: 1ph 50Hz 750w 1500rpm N: 1ph 60Hz 750w 1500rpm |

MODELS

| | Code | Motor | | Dimensions | | | | | | Agitation | | | |
|--------|---------------------------|-------|------|------------|-----|--------|--------|------|--------|----------------|------|-------------------|------|
| | | Watts | rpm | L | Ø T | Ø Dmax | Volume | Flow | Volume | Flow | | | |
| | | | | mm | in | mm | in | m | in | m ³ | gal | m ³ /h | gpm |
| Flange | 3ph 50Hz 70-LB-A1500-T15P | 750 | 1400 | 1500 | 59 | 150 | 5.9 | 2.7 | 106 | 10 | 2600 | 8.3 | 36.5 |
| | 3ph 60Hz 70-LB-A1500-T13P | 900 | 1650 | 1500 | 59 | 130 | 5.1 | 2.7 | 106 | 10 | 2600 | 8.0 | 35.2 |
| | 1ph 50Hz 70-MB-A1500-T15P | 750 | 1400 | 1500 | 59 | 150 | 5.9 | 2.7 | 106 | 10 | 2600 | 8.3 | 36.5 |
| | 1ph 60Hz 70-NB-A1500-T13P | 900 | 1650 | 1500 | 59 | 130 | 5.1 | 2.7 | 106 | 10 | 2600 | 8.0 | 35.2 |
| Clamp | 3ph 50Hz 70-LP-A1500-T15P | 750 | 1400 | 1500 | 59 | 150 | 5.9 | 2.7 | 106 | 10 | 2600 | 8.3 | 36.5 |
| | 3ph 60Hz 70-LP-A1500-T13P | 900 | 1650 | 1500 | 59 | 130 | 5.1 | 2.7 | 106 | 10 | 2600 | 8.0 | 35.2 |
| | 1ph 50Hz 70-MP-A1500-T15P | 750 | 1400 | 1500 | 59 | 150 | 5.9 | 2.7 | 106 | 10 | 2600 | 8.3 | 36.5 |
| | 1ph 60Hz 70-NP-A1500-T13P | 900 | 1650 | 1500 | 59 | 130 | 5.1 | 2.7 | 106 | 10 | 2600 | 8.0 | 35.2 |

DIMENSIONS

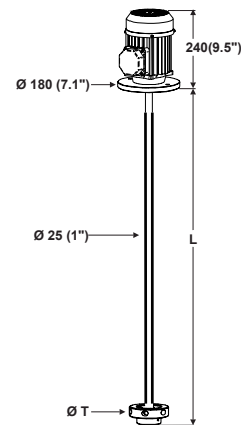
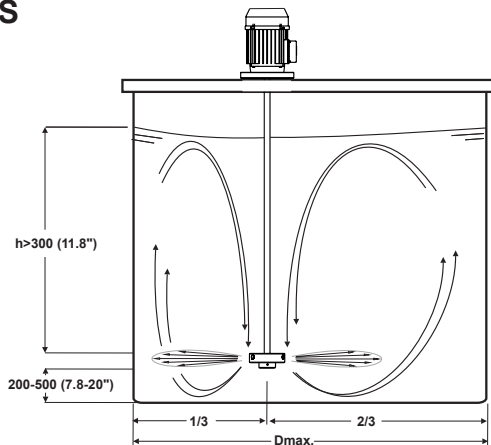

MATERIALS

| | |
|---------|---------------|
| Turbine | PP |
| Shaft | AISI 304 / PE |
| Screws | AISI 304 |
| Flange | PP |

MOTOR

| | 3ph |
|------------|-------------|
| Power | 750W (1Hp) |
| Voltage | 230V - 430V |
| Current | 3.4A - 2A |
| Frequency | 50Hz - 60Hz |
| r.p.m | 1400 - 1650 |
| Protection | IP-55 |
| Class | F |
| Frame | T80 B14 |