

MF: TECHNICAL FEATURES

CODE FORMULATION

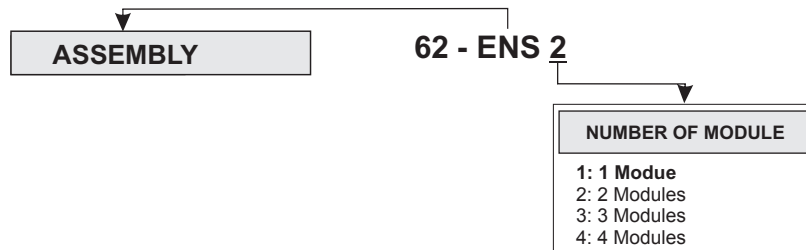
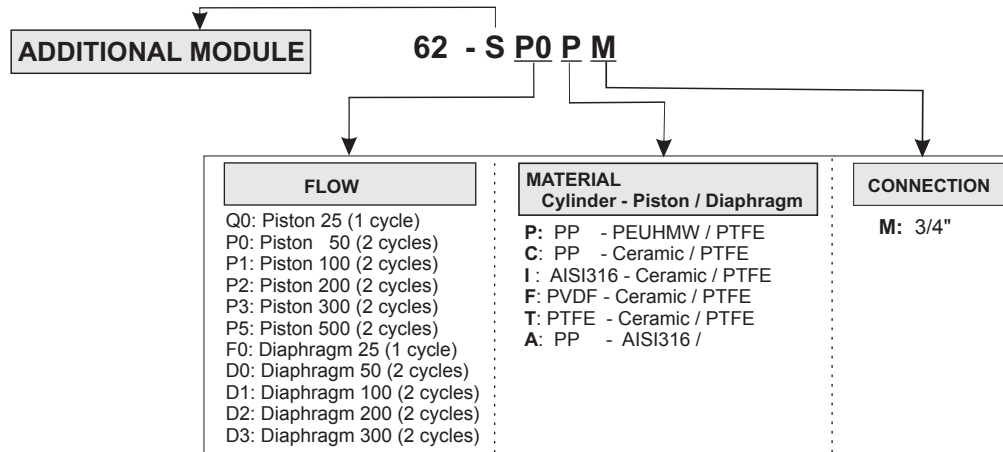
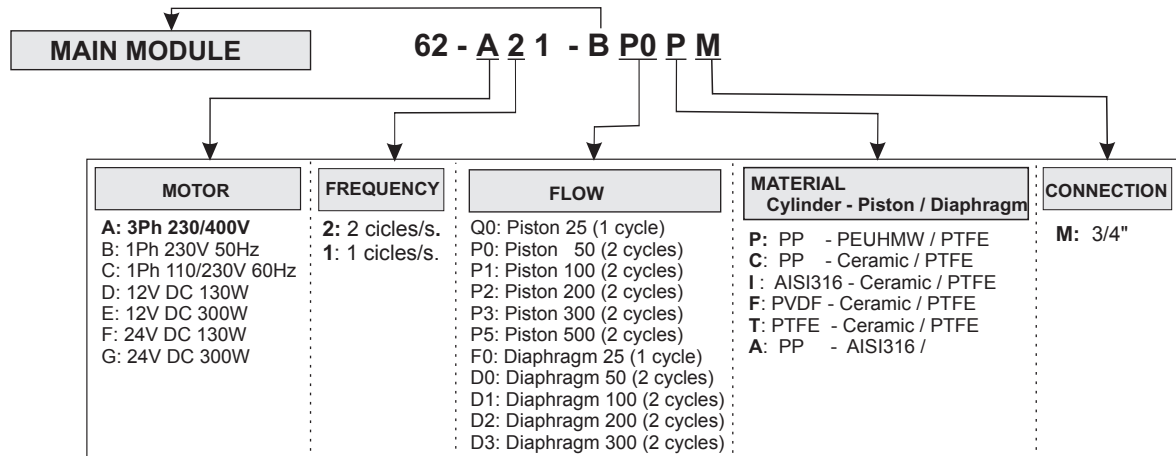
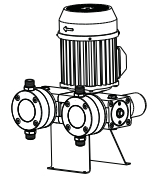

FLOW - PRESSURE

	CODE	FLOW				PRESSURE	
		50Hz		60Hz		bar	PSI
		l/h	GPH	l/h	GPH		
Piston 	62-A11-BQ0_M	25	6,6	30	7.5	15	217
	62-A21-BP0_M	50	13	60	15	15	217
	62-A21-BP1_M	100	26	120	30	15	217
	62-A21-BP2_M	200	53	240	60	8	116
	62-A21-BP3_M	300	79	360	90	5	73
	62-A21-BP5_M	500	132	600	150	3	43

	CODE	FLOW				PRESSURE	
		50Hz		60Hz		bar	PSI
		l/h	GPH	l/h	GPH		
Diaphragm 	62-A11-BF0_M	25-18,5	6.6-4.9	30-22.2	7.5 - 5,7	10	145
	62-A21-BD0_M	50-37	13,2-9,8	60-44,4	15 - 11	10	145
	62-A21-BD1_M	100-86	26,4-22,7	120-103	30 - 27	10	145
	62-A21-BD2_M	200-165	52.8-43,5	240-198	60 - 50	6	87
	62-A21-BD3_M	300-245	79 - 65	360-294	90 - 78	4	58

MF: TECHNICAL FEATURES

ELECTRIC CURRENT: As indicated in the motor plate

POWER: 0.37 KW (0.5 CV)

PROTECTION : IP-55

MATERIALS:

- Piston: PEUAPM / Ceramic
- Diaphragm: Elastomer base reinforced with fiber and PTFE clothing
- Cylinder: PP / PVDF / AISI 316
- Valves(body): PP / PVDF / AISI 316
- Valves(ball) : Glass / glass borosilicato / Ceramic
- Retention: FPM

NOISE LEVEL dB(A): minor than 70

DIMENSIONS

mm

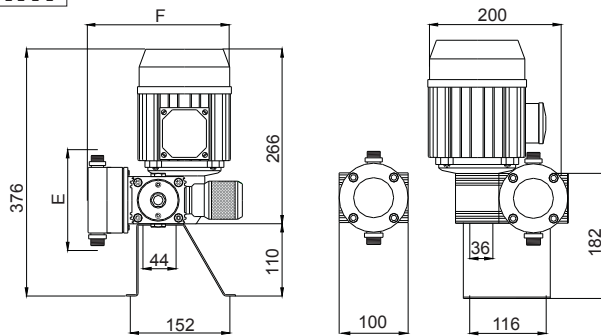



Piston 		
I/h	E	F
50-100	154	255
200-300	154	255
500	170	270

Diafragma 		
I/h	E	F
50-100	154	213
200	184	218
300	204	218

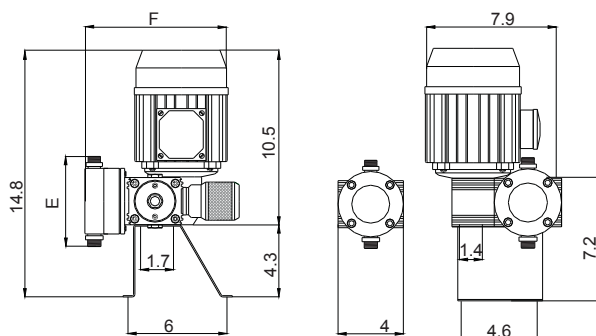
in



Piston 		
I/h	E	F
50-100	6.1	10
200-300	6.1	10
500	6.7	10.6

Diafragma 		
L/h	E	F
50-100	6,1	8,4
200	7,2	8,6
300	8	8,6

INJECTION MODULES

		DIMENSIONS		WEIGHT	
		mm	in	Kg	lb
1	A	200	7.9	12	26.5
2	B	265	10.5	14.5	32
3	C	365	15	17	37.6
4	D	465	18.3	19.5	43

